

Category K (05)	Applicable Model/s All Models	Subject AUTOMATIC TRANSMISSION COOLER/LINE FLUSHING PROCEDURE	Bulletin No.	005/98
			Issued	04/22/98
			Revised	12/31/98

### BULLETIN NOTE

- This bulletin supersedes K 005/98 dated 04/22/98. The REPAIR PROCEDURE and WARRANTY INFORMATION has been revised.

### APPLICABLE MODEL(S)/VINS

All models with automatic transmission.

### DESCRIPTION

Automatic transmission (A/T) oil cooler/lines must be power flushed completely before an overhauled or replacement A/T is installed. One of the causes of repeat A/T failures is an internal automatic transmission fluid (ATF) restriction at the inlet side of the oil cooler. This restriction is usually caused by an accumulation of metal particles and debris (from a previous A/T failure) on the internal mesh type baffle of the oil cooler. Power flushing will remove the restriction by back flushing the cooler/lines followed by forward flushing to ensure full ATF flow. See **FIGURE 1** of a typical ATF cooler.

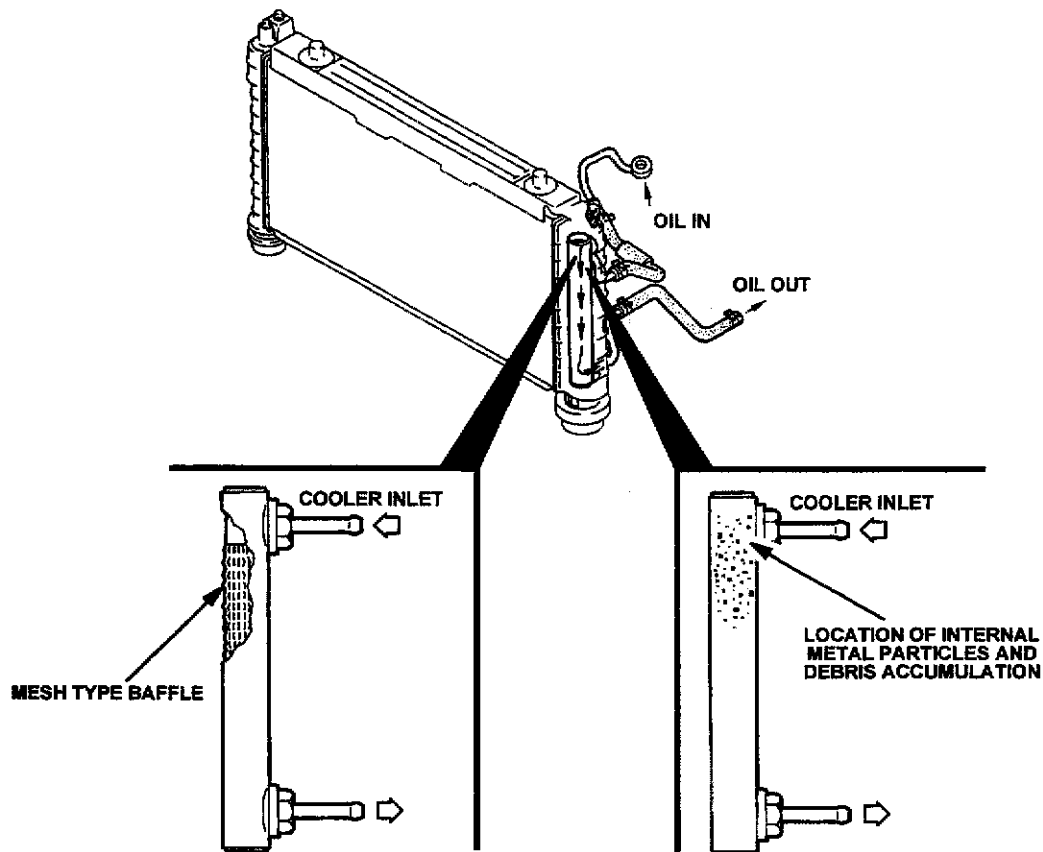

FIGURE 1

**060403**

**CONSUMER NOTICE:** The information and instructions in this bulletin are intended for use by skilled technicians. Mazda technicians utilize the proper tools / equipment and take training to correctly and safely maintain Mazda vehicles. These instructions should not be performed by "do-it-yourselfers." Consumers should not assume this bulletin applies to their vehicle or that their vehicle will develop the described concern. To determine if the information applies, consumers should contact their nearest authorized Mazda dealership.

Number: 005/98	Date Issued: 04/22/98	Revised: 12/31/98
----------------	-----------------------	-------------------

**Caution**

- Repeat repairs caused by improper or lack of cooler line flushing will not be covered under warranty.

**Recommended Power Flushing Equipment**

Part Number	Description
J35944-AMAZ	Kent-Moore Flusher w/Mazda Adaptors
60081-M	OTC Flusher w/Mazda Adaptors

**REPAIR PROCEDURE**

Before power flushing, inspect the hoses/lines and clamps. Power flushing must begin with back flushing followed by forward flushing to quickly dislodge the restriction. If back flushing is not performed before forward flushing, the restriction could further reduce the ATF flow through the internal mesh type baffle of the cooler and flushing will not be effective or possible.

**Inspecting Oil Lines & Clamps**

Be sure to inspect the lines (hoses/pipes) for cuts, crimps (pinched), cracks or any other damage before reusing them. If any problem exists or the hose comes off when applying oil pressure, replace it.

**Caution**

- Always use new clamps when replacing hoses.

**Back Flushing**

1. Using the Power Flushing Equipment manufacturer's instructions, connect equipment so the flushing fluid flows in the opposite direction of normal fluid flow. Refer to page 4 to determine normal fluid flow. See typical example of back flushing flow in *Figure 2*.
2. Flush oil cooler/lines until discharge fluid is clean.

**Caution**

- If the cooler can not be properly flushed using recommended equipment, send the radiator out for sublet cleaning or replace.

**Note**

- Refer to the WSM or Automatic Transmission Quick Reference Guide (P/N 9999-95-4501-96) for exact location of cooler line inlet./ outlet fittings.

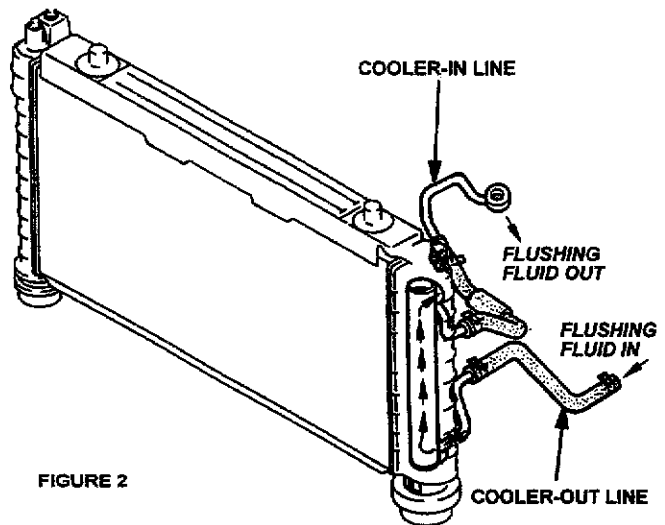

FIGURE 2

**Forward Flushing**

3. Connect power flushing equipment so the flushing fluid flows in the direction of normal fluid flow. Refer to page 4 to determine fluid flow. See typical example of forward flushing flow in **FIGURE 3**.
4. Flush oil cooler/lines until discharge fluid is clean.

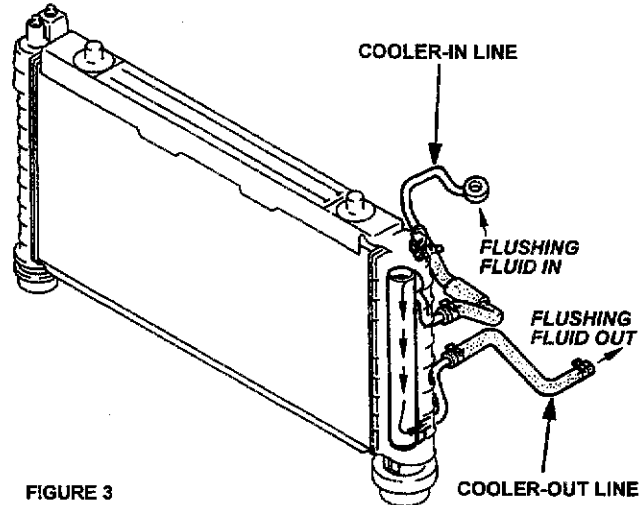

FIGURE 3

**WARRANTY INFORMATION****Note**

- This information applies to verified customer complaints on vehicles covered under normal warranty. Refer to the SRT microfiche for warranty term information.
- When you submit a warranty claim on automatic transmission complete replacement, add any of the following operation numbers and labor hours to the operation number and labor hours for automatic transmission complete R&R.

**Operation Number / Labor Hours:**

MPV L4 = K0101XRU/0.4

MPV V6 2WD = K0101XRU/0.4

MPV V6 4WD = K0101XRU/0.4

Millenia 2.3L = K0101XRU/0.4

Millenia 2.5L = K0101XRU/0.4

RX-7 = K0101XRU/0.4

MX-5 = K0101XRU/0.4

MX-3 L4 = K0101ARU/0.4

MX-3 V6 = K0101BRU/0.4

929 = K0101XRU/0.4

626/MX-6 L4 = K0101XRU/0.4

626/MX-6 V6 = K0101XRU/0.4

Protege/323 2WD, 1.6L &amp; 1.8L = K0101XRU/0.4

Protege/323 2WD, 1.5L = K0101XRU/0.4

Protege/323 4WD = K0101XRU / 0.4

B-Series 2.3L = K0101ARU / 0.4

B-Series 2.5L = K0101BRU / 0.4

B-Series 3.0L (4X4) = K0101CRU / 0.4

B-Series 3.0L (4X2) = K0101DRU / 0.4

B-Series 4.0L (4X4) = K0101ERU / 0.4

B-Series 4.0L (4X2) = K0101FRU / 0.4

Navajo (4X4) = K0101ERU / 0.4

Navajo (4X2) = K0101FRU / 0.4

# Typical Automatic Transmission/Transaxle Normal Fluid Flow & Cooler Line Fitting Locations

(Refer to applicable WSM for specific details.)

## FRONT WHEEL DRIVE (TRANSAXLE)

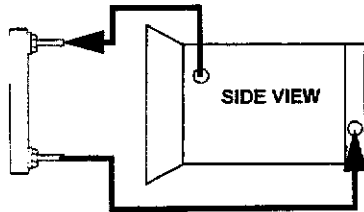

PROTEGE, MILLENIA (KL), 626 (FS)

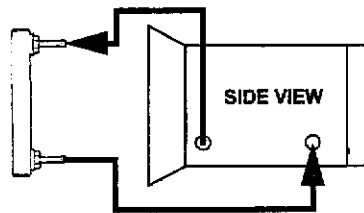

MILLENIA (KJ)

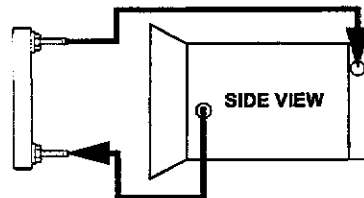

626 (KL)

## REAR WHEEL DRIVE

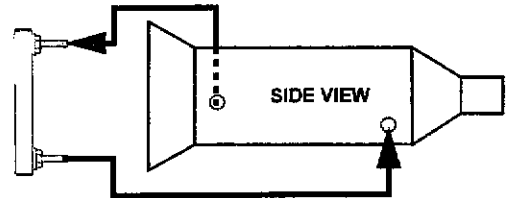

MPV, RX-7, 929, MIATA (NA)

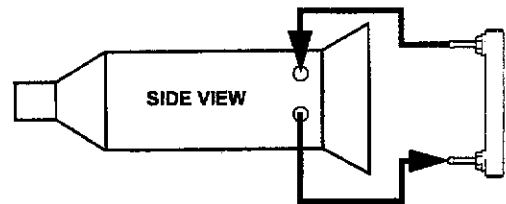

B-TRUCKS

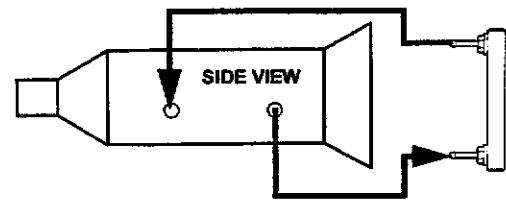

MIATA (NB)